



FIRE

REZONTECH

FLAME

DETECTOR

User Manual



● UV/IR TYPE

- RFD-2T
- RFD-2FT
- RFD-2TN- I
- RFD-2FTN
- RFD-2FTN- I

● IR3 TYPE

- RFD-3FT
- RFD-3FT- I



805, Mega Valley, Gwangyang-dong, Dongan-gu,
Anyang-si, Gyeonggi-do, Korea
TEL : +82-1544-9108 FAX : +82-31-420-0800

INTRO

Rezontech inc. was founded to take charge of parts what ensure against risks that chief obstacles to embody more safe tomorrow of humankind, sudden disaster, especially fire.

Today, complexity of industrial society causes more destructive fire. It's going fatal and fatal to whole establishment or environment even though partial fire. The importance is embossed more and more about early detection of fire because growth of threat is increasing in geometrical series.

However, insufficiency of disaster prevention causes loss of life and property. It meets the demands of times, needs of flame detector is increasing to early fire detection.

For the reason, we developed flame detector ourselves, moreover equipment of disaster prevention and system, to great service to protect customer's life and properties from fire and other disasters.

We'll do our best to be the head of 21st century disaster prevention technology to protect national infrastructure and customer's properties from continuous technical development what makes the prevention equipment,

intelligent, hereafter.

- **Product contains** 5
 - Product constitution
 - Names of parts
- **Specifics by products** 7
 - UV/IR TYPE 7
 - RFD-2T
 - RFD-2FT
 - RFD-2TN- I
 - RFD-2FTN
 - RFD-2FTN- I
 - IR3 TYPE 19
 - RFD-3FT
 - RFD-3FT- I
- **Installation** 25
 - Electrical wire coupling by signal of product
 - Electrical wire coupling with general receiver
 - Recommend wire standardized
 - Fix on swivel mount (Bracket)
 - Installation of flame detector (construction)
- **Product test and signal indication** 43
 - Product test
 - LED indicate (display) by situation and output
- **The supplement** 47
 - Accessories
 - Test equipment
 - How to use the test lamp
 - Test method with fire source

Product Contains

Specifics by Products

Product Installation

Product Test and Signal Indication

The Supplement

Product contains



WWW.REZONTECH.COM



Product constitution



Names of parts

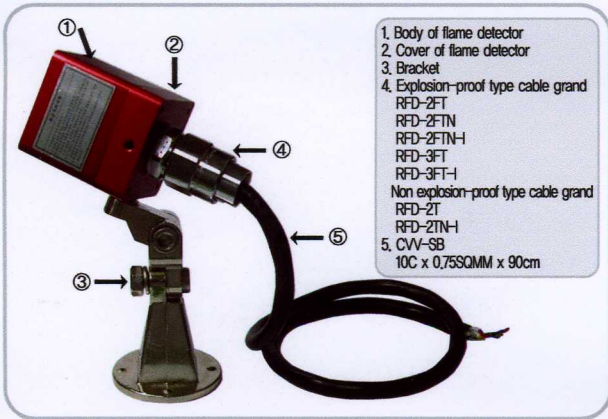

UV/IR Type

The flame detectors of this type use UV/IR rays to detect fire or outbreaks of flame and make alarm signal or activate the extinguishing system, this function can be supported from direct outlet of sensor or connected control circuit.



RFD-2T



RFD-2FT



RFD-2FTN



RFD-2FTN-I



RFD-2TN-I

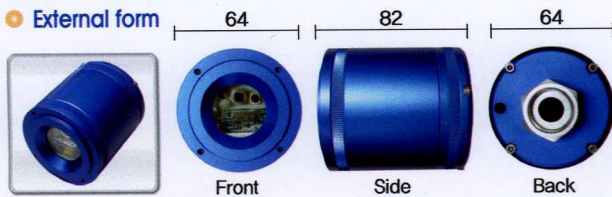

Special Feature

- Type : UV/IR Type, Outdoor, Non explosion-proof
- Nominal sensing range : 25M
- Sensing angle : 90°C, Cone type
- Environment
 - ▶ Operating temp : -20~+60°C ▶ Keeping temp : -20~+70°C
 - ▶ Humidity: 10~90%
- Output signal
 - ▶ RELAY-FILE : 0.2A(AC250V), A point of connect
 - ▶ 0.5A(DC 30V), A point of connect

Function

- 4 steps selective sensitivity
- Fail check available - self diagnosis

Structure

- Material : Aluminum 6061
- Surface : Anodizing Process
- Color : Blue
- Weight : About 0.4kg
- External : 64mm×82mm, Cylindrical, Connector 1/2" PF
- Terminal connection standard : AWG 25~16 (0.13mm²~1.5mm²)

Electrical

- Power consumption : 4.8W
- Voltage : DC 24V(17~30V, pulsating current available)
- Current
 - ▶ Normal(Sensing) : 90mA
 - ▶ Fire detected : 120mA
 - ▶ Self test : 150mA

Function of switches

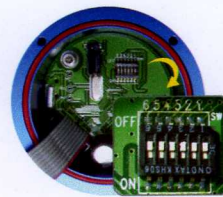

- Sensitivity switch : Switch No.1 and 2
 - Time delay switch : Switch No.3 and 4
 - Signal maintaining switch On/Off : Switch No.5
 - Self diagnosis switch On/Off : Switch No.6
- (Switch No.5 and 6 are off on delivery)

※ refer to page 46 to get more details

Terminals

terminal	signal	function indicates
1	+ Power	+ 24V
2	- Power	GND
3	Relay Common	COM
4	Relay A Connection	N.O



output signal

Sensor state		LED	Relay (N.O)
Error	Low Voltage	Green Blinks	Open
	Self Diagnosis	Orange Blinks	Open
Idle		Green On	Open
Fire		Red On	Close



External form

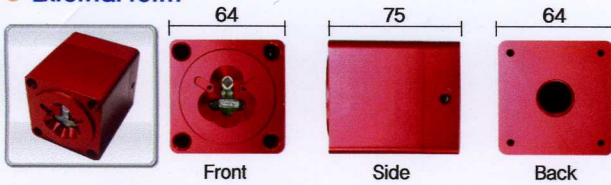

- Special feature**
- Type : UV/IR Type, Outdoor, Explosion-proof
 - Nominal sensing range : 25M
 - Sensing angle : 90°, Cone type
 - Environment : ▶Operating temp : -40~+80°C
▶Keeping temp : -50~+90°C ▶Humidity : 10~90%
 - Explosion-proof class : Exd I C T6 IP66(KGS)
 - Output signal : ▶RELAY
 - ▶Fire : 5A(250VAC, 30VDC), A Connect point
 - ▶O.C (Open Collector)
 - Fire : MAX DC 32V, 10mA
 - Error : MAX DC 32V, 10mA
 - ▶4~20mA ▶RS485

- Function**
- 4 steps selective sensitivity
 - Fail check available - self diagnosis

- Structure**
- Material : Aluminum 6061
 - Surface : Anodizing Process
 - Color : Red • Weight : About 0.53kg
 - External : 64mm×75mm, Hexahedral, Connector ½" PF
 - Terminal connection standard : AWG25~16(0.13mm~1.5mm)

- Electrical**
- Power Consumption : 5.4W
 - Voltage : DC 24V (17~30V, pulsating current available)
 - Current
 - ▶Normal(Sensing) : 100mA
 - ▶Fire detected : 140mA
 - ▶Self test : 170mA

Function of switches



- Sensitivity switch : Switch No.1 and 2
 - Time delay switch : Switch No.3 and 4
 - Signal maintaining switch On/Off : Switch No.5
 - Self diagnosis switch On/Off : Switch No.6
- (Switch No.5 and 6 are off on delivery)

Terminals

terminal	signal	function indicates
1	+ Power	+ 24V
2	Current signal	4~20mA
3	-Power	GND
4	O.C fire signal	Fire
5	O.C error signal	Error
6	-Communication	RS485 -
7	+Communication	RS485 +
8	Relay Common com	COM
9	Relay A connection	N.O



output signal

Sensor state		LED	O.C fire	O.C Error	RELAY(N.O)
Error	Low Voltage	Green blinks	Open	Open	Open
	Self diagnosis	Green blinks Orange blinks	Open	Open	Open
Idle		Green On	Open	Close	Open
Fire		Red On	Close	Close	Close

Specifics by Products



External form

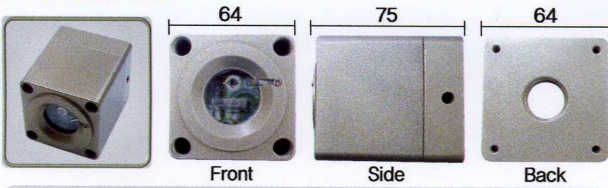

Special feature

- Type : UV/IR Type, Indoor, Non explosion-proof
- Nominal sensing range : 30m
- Sensing angle : 100°, Cone type
- Environment : ▶Operating temp : -40~+80℃
▶Keeping temp : -50~+90℃ ▶Humidity : 10~90%
- Casing class : IP66
- Output signal :
- ▶RELAY
 - Fire : 1A(250VAC, 30VDC), A-Bconnect point
 - Error : 1A(250VAC, 30VDC), A-Bconnect point
- ▶4~20mA ▶RS485

Function

- 4 steps selective sensitivity
- Fail check available - self diagnosis
- Remote self diagnostic ON/OFF control (BIT)

Structure

- Material : Aluminum Diecasting
- Surface : Powder Coating
- Color : Gold
- Weight : About 0.54kg
- External : 64mm×75mm, Hexahedral, Connector ½" PF

Electrical

- Power Consumption : 5.4W
- Voltage : DC 24V (17~30V, pulsating current enable)
- Current
 - ▶Nomal(Sensing) : 100mA
 - ▶Fire detected : 120mA
 - ▶Self test : 180mA

Function of switches

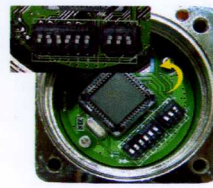

- Sensitivity switch : Switch No.1-1 and 2
- Time delay switch : Switch No.1-3 and 4
- Signal maintaining switch On/Off : Switch No.1-5
- Self diagnosis switch On/Off : Switch No.1-6
(Switch No.5 and 6 are off on delivery)
- LED display select : Switch No.2-2
(Display sensing states which IR or UV)

Terminals

Terminal	signal	function indicates
1	+Power	+ 24V
2	Fire signal common	F-COM
3	Fire signal B connect	F-N,C
4	Fire signal A connect	F-N,O
5	- Power	GND(-)
6	Sensor test terminal	BIT
7	RS485 -	RS485 -
8	RS485 +	RS485 +
9	Error signal B/A connect	S-N,C/N,O
10	Error signal common	S - COM
11	Current signal	4 - 20mA

Ⓜ Error signal select jumper : Default N.O

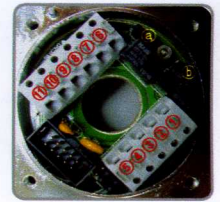

output signal

Sensor state		LED	Fire relay (N.O)	Error relay(N.O)
Error	Low Voltage	Green blinks	Open	Open
	Self diagnosis	Green blinks Red blinks	Open	Open
Idle		Green On	Open	Close
IR detected		Red blinks 4times/sec	Open	Close
UV detected		Red blinks 2times/sec	Open	Close
Alarm		Red blinks	Open	Close
Fire		Red On	Close	Close



External form

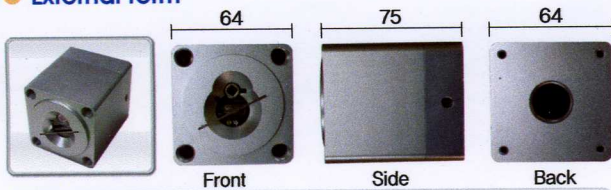

Special feature

- Type : UV/IR Type, Outdoor, Explosion-proof
- Nominal sensing range : 30m
- Sensing angle : 100°, Cone type
- Environment : ▶Operating temp : -40~+80°C ▶Keeping temp : -50~+90°C
▶Humidity : 10~90%
- Explosion-proof class : Exd IIC T6 IP66(KGS)
- Output signal : ▶RELAY
 - Fire : 1A(250VAC, 30VDC), A-B connect point
 - Error : 1A(250VAC, 30VDC), A-B connect point
- ▶4~20mA ▶RS485

Function

- 4 steps selective sensitivity
- Fail check available - self diagnosis
- Remote self diagnostic ON/OFF control (BIT)

Structure

- Material : Aluminum 6061
- Surface : Anodizing Process
- Color : White silver
- Weight : About 0.53kg
- External : 64mm x 75mm, Hexahedral, Connector 1/2" PF

Electrical

- Power Consumption : 5.4W
- Voltage : DC 24V (17~30V, Pulsating current available)
- Current
 - ▶Nomal(Sensing) : 100mA
 - ▶Fire detected : 120mA
 - ▶Self test : 170mA

Function of switches

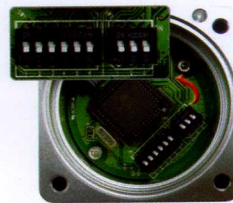

- Sensitivity switch : Switch No.1-1 and 2
- Time delay switch : Switch No.1-3 and 4
- Signal maintaining switch On/Off : Switch No.1-5
- Self diagnosis switch On/Off : Switch No.1-6
(Switch No.5 and 6 are off on delivery)
- LED display select : Switch No.2-2
(Display sensing states which IR or UV)

Terminals

Terminal	signal	function indicates
1	+Power	+ 24V
2	Fire signal common	F-COM
3	Fire signal B connect	F-N.C
4	Fire signal A connect	F-N.O
5	- Power	GND(-)
6	Sensor test terminal	BIT
7	RS485 -	RS485 -
8	RS485 +	RS485 +
9	Error signal B/A connect	S-N.C/N.O
10	Error signal common	S - COM
11	Current signal	4 - 20mA

© Error signal select jumper : Default N.O



output signal

Sensor states		LED	Fire relay (N.O)	Error relay(N.O)
Error	Low Voltage	Green blinks	Open	Open
	Self diagnosis	Green blinks Red blinks	Open	Open
Idle		Green On	Open	Close
IR detected		Red blinks 4times/sec	Open	Close
UV detected		Red blinks 2times/sec	Open	Close
Alarm		Red blinks	Open	Close
Fire		Red On	Close	Close

Specifics by Products



External form

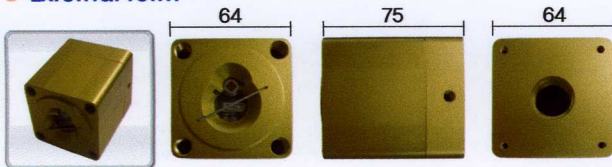

Special feature

- Type : UV/IR Type, Indoor, Explosion-proof
- Nominal sensing range : 30m
- Sensing angle : 100°, Cone type
- Environment : ▶Operating temp : -40~+80°C ▶Keeping temp : -50~+90°C
▶Humidity : 10~90%
- Explosion-proof class : Exd IIC T6 IP66(KGS)
- Output signal : ▶RELAY
 - Fire : 1A(250VAC, 30VDC), A-B connect point
 - Error : 1A(250VAC, 30VDC), A-B connect point
- ▶4~20mA ▶RS485

Function

- 4 steps selective sensitivity
- Failure check available – self diagnosis
- Remote self diagnostic ON/OFF control (BIT)

Structure

- Material : Aluminum 6061
- Surface : Anodizing Process
- Color : Gold
- Weight : About 0.53kg
- External : 64mm×75mm, Hexahedral, Connector ½” PF

Electrical

- Power Consumption : 5.4W
- Voltage : DC 24V (17~30V, Pulsating current available)
- Current
 - ▶Nomal(Sensing) : 100mA
 - ▶Fire detected : 140mA
 - ▶Self test : 170mA

Function of switches



- Sensitivity switch : Switch No.1 and 2
- Time delay switch : Switch No.3 and 4
- Signal maintaining switch On/Off : Switch No.5
- Self diagnosis switch On/Off : Switch No.6
(Switch No.5 and 6 are off on delivery)

Terminals

Terminal	signal	function indicates
1	+Power	+ 24V
2	Fire signal common	F-COM
3	Fire signal B connect	F-N.C
4	Fire signal A connect	F-N.O
5	- Power	GND(-)
6	Sensor test terminal	BIT
7	RS485 -	RS485 -
8	RS485 +	RS485 +
9	Error signal B/A connect	S-N.C/N.O
10	Error signal common	S - COM
11	Current signal	4 - 20mA



output signal

Sensor state		LED	Fire relay (N.O)	Error RELAY(N.O)
Error	Low Voltage	Green blinks	Open	Open
	Self diagnosis	Green blinks Red blinks	Open	Open
Idle		Green On	Open	Close
IR detected		-	Open	Close
UV detected		-	Open	Close
Alarm		Red blinks	Open	Close
Fire		Red On	Close	Close

Multi Spectrum IR3 Type

The IR3 flame detectors adopt sensors which are optically high-sensitive about three separated radiation spectrums in fire.



RFD-3FT



RFD-3FT-I



External form

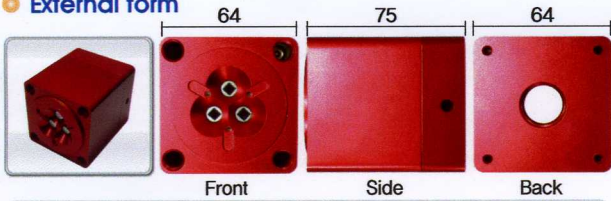

Special feature

- Type : IR3 Type , Outdoor, Explosion-proof
- Nominal sensing range : 50m
- Sensing angle : 90° , Cone type
- Environment : ▶Operating temp : -40~+80°C ▶Keeping temp : -50~+90°C
▶Humidity : 10~90%
- Explosion-proof class : Exd IIC T6 IP66(KGS)
- Output signal :
 - ▶RELAY - Fire : 5A (250VAC, 30VDC), A connect point O.C(Open Collector)
 - ▶Error : MAX DC 32V, 10mA ▶4~20mA ▶RS485

Function

- 4 steps selective sensitivity
- Fail check available - self diagnosis

Structure

- Material : Aluminum 6061
- Surface : Anodizing Process
- Color : Red
- Weight : about 0.53kg
- External : 64mm×75mm, Hexahedral, Connector 1/2" PF

Electrical

- Power Consumption : 3.8W
- Voltage : DC 24V (17~30V, pulsating current available)
- Current
 - ▶Normal(Sensing) : 75mA
 - ▶Fire detected : 90mA
 - ▶Self test : 120mA

Function of switches

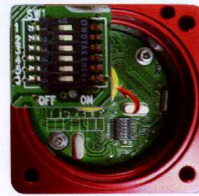

- Sensitivity switch : Switch No.1 and 2
- Time delay switch : Switch No.3 and 4
- Signal maintaining switch On/Off : Switch No.5
- Self diagnosis switch On/Off : Switch No.6
(Switch No.5 and 6 are off on delivery)

Terminals

Terminal	signal	function indicates
1	+Power	+ 24V
2	Current signal	4~20mA
3	-Power	GND
4	O.C error signal	Error
5	-Communication	RS485 -
6	+Communication	RS485 +
7	Relay Common com	COM
8	Relay A connection	N.O



output signal

Sensor state		LED	O.C error	RELAY(N.O)
Error	Low Voltage	Blue blinks	Open	Open
	Self diagnosis	Blue blinks	Open	Open
Idle		Green On	Close	Open
Fire		Red On	Close	Close



External form

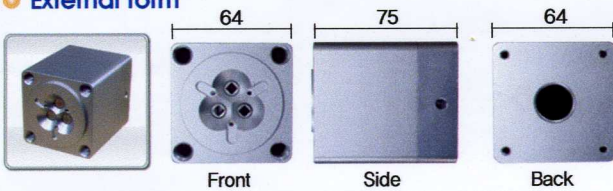

Special feature

- Type : IR3 Type , Indoor, Water-proof, Explosion type
- Nominal sensing range : 50m
- Sensing angle : 90°, Cone type
- Environment : ▶Operating temp : -40~+80°C ▶Keeping temp : -50~+90°C
▶Humidity : 10~90%
- Explosion-proof class : Exd II C T6 IP66(KGS)
- Output signal :
 - ▶RELAY - Fire : 5A (250VAC, 30VDC), A connect point
 - ▶Error : MAX DC 32V, 10mA
 - ▶4~20mA ▶RS485

Function

- 4 steps selective sensitivity
- Fail check available - self diagnosis

Structure

- Material : Aluminum 6061
- Surface : Anodizing Process
- Color : White silver
- Weight : about 0.53kg
- External : 64mm×75mm, Hexahedral, Connector ½" PF

Electrical

- Power Consumption : 3.8W
- Voltage : DC 24V (17~30V, pulsating current available)
- Current
 - ▶Normal(Sensing) : 75mA
 - ▶Fire detected : 90mA
 - ▶Self test : 120mA

Function of switches



- Sensitivity switch : Switch No.1 and 2
- Time delay switch : Switch No.3 and 4
- Signal maintaining switch On/Off : Switch No.5
- Self diagnosis switch On/Off : Switch No.6
(Switch No.5 and 6 are off on delivery)

Terminals

Terminal	signal	function indicates
1	+Power	+ 24V
2	Current signal	4~20mA
3	-Power	GND
4	O.C error signal	Error
5	-Communication	RS485 -
6	+Communication	RS485 +
7	Relay Common com	COM
8	Relay A connection	N.O

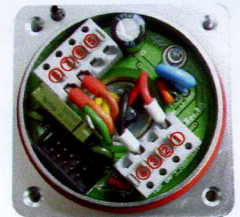

output signal

Sensor state		LED	O.C error	RELAY(N.O)
Error	Low Voltage	Blue blinks	Open	Open
	Self diagnosis	Blue blinks	Open	Open
Idle		Green On	Close	Open
Fire		Red On	Close	Close

INSTALLATIONS

● Specifics of signal types

● O.C Output (Open Collector)

- This circuit is transistor, not relay.
- The terminal connects or opens to GND(power) max. 32V, 10mA electrical current output when fire or fault occurs.

Situation	Idle	Alarm	Maximum Connection Class
Fire	Open	Close	DC 32V 10mA
Fault	Close	Open	DC 32V 10mA

※Specifics & attention (Inquire us when you want to use relay)

- O.C Fire output is designed to connect with P type receiver
- A 330Ω resistor is connected with series circuit to limit the current

O.C Output signal	Inner diagram of terminal circuit	Receiver or junction
Fire Fault		Fire, Fault terminal -Connect with power(GND)
O.C Output signal	Inner diagram of equal value circuit	Receiver or junction
Fire Fault		Fire, Fault terminal -Connect with power(GND)

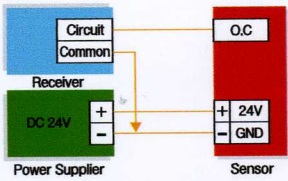

O.C Output wire coupling - 3 wiring

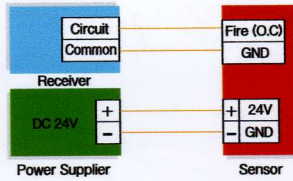

O.C Output wire coupling - 4 wiring

● Relay output(Point of connection)

	Idle	Fault	Fire	Class
Fire alarm	Open	Open	Close	Open : 500MΩ at DC 500V Close : 1A (DC 30V)
Falut alarm	Close	Open	Close	

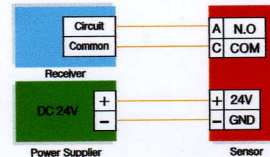
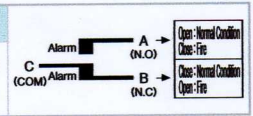

Relay Output wire coupling - 4 wiring

● 4~20mA Output

- The method of signal transmission using current signal level, it should be resistor (Max.500Ω at DC24V)connected.

• 4~20mA Signal level

State	Output(mA, ±5%)	Explanation
Connection fail	0mA	Wire connection fault or cut
Sensing fail	2mA	Sensor has a problem(self diagnosis is engaged)
Idle	4mA	It's stand by in regularity
Power fail	6mA	Unstable power supplied under 17V
IR detection	8mA	IR detected
UV detection	12mA	UV detected (UV/IR type)
Alarm signal	16mA	Source of fire detected
Fire alarm	20mA	Fire detected

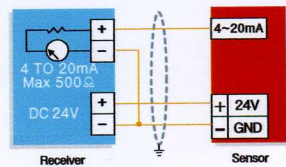

4~20mA current output wire coupling (Non-Isolation)

Product Installation

● Wire coupling with general receiver(P type, R type, receiver, junction)

● 4wires coupling (2 for power, 2 for signal)

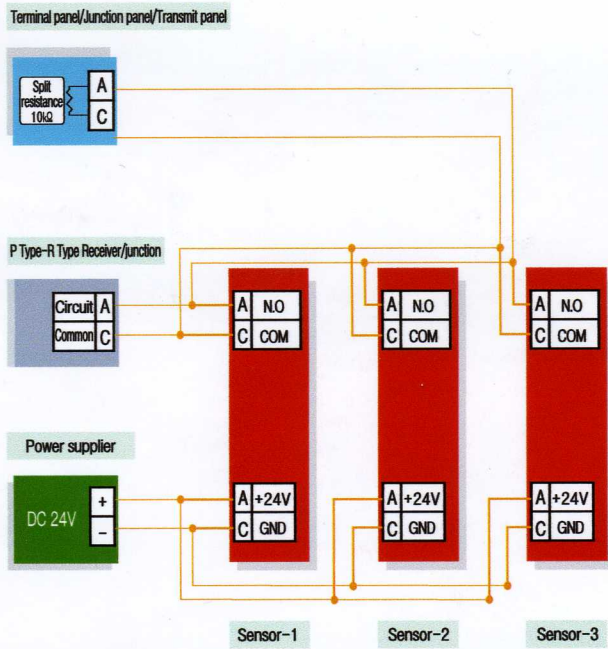

[In case of coupling for several sensors with a circuit (external split resistance)]

● 4wires coupling (2 for power, 2 for signal)

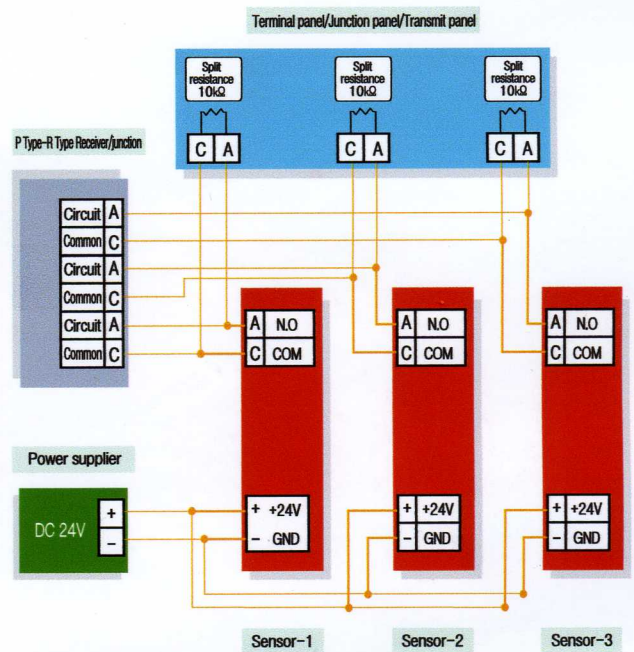

[In case of coupling for several sensors with a circuit (external split resistance)]

Product Installation

● 4wires coupling (2 for power, 2 for signal)

● 6wires coupling (2 for power, 4 for signal)

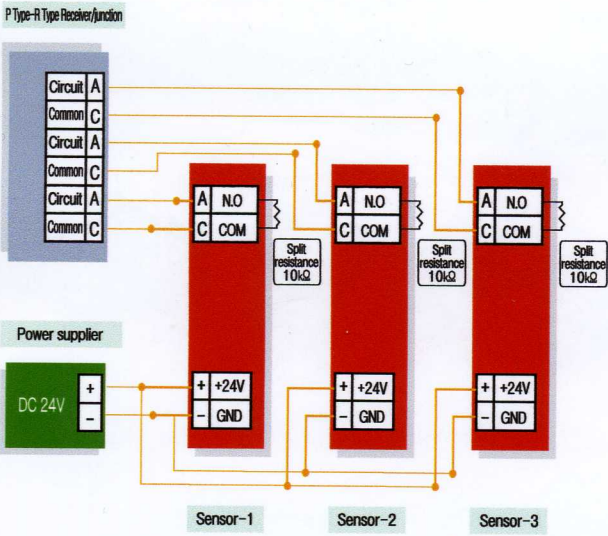

[In case of coupling for several sensors with a circuit (external split resistance)]

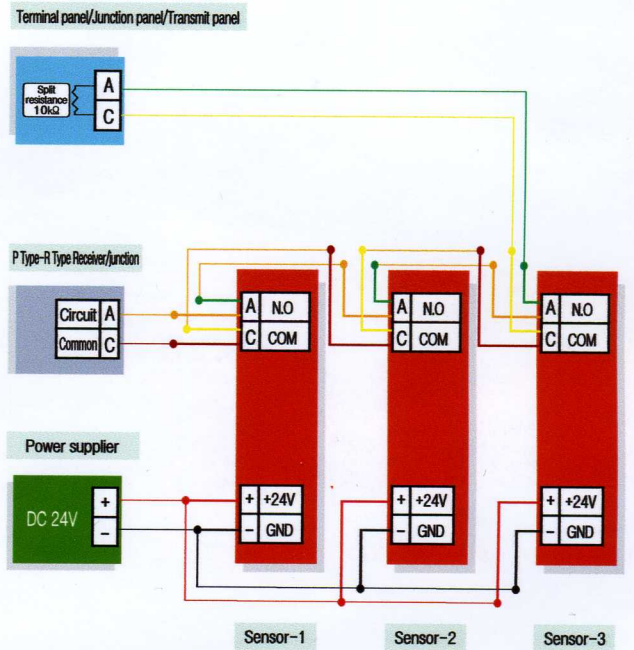

[In case of coupling for several sensors with a circuit (external split resistance)]

Product Installation

● 6wires coupling (2 for power, 4 for signal)

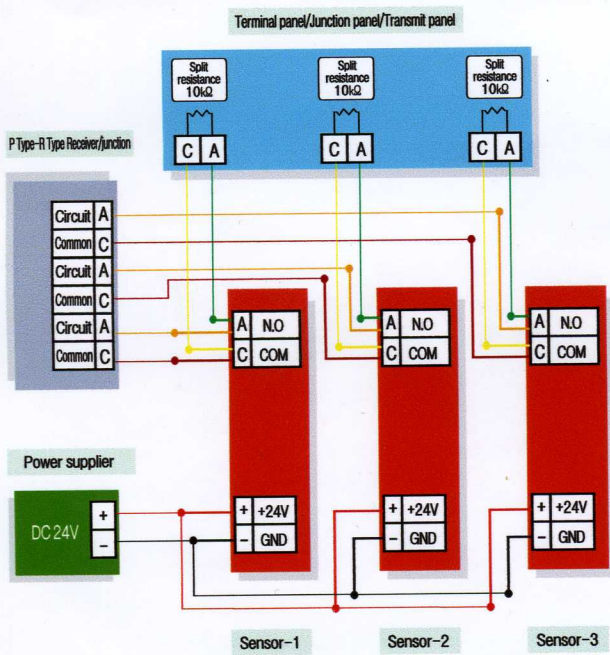

[In case of coupling for several sensors with a circuit (external split resistance)]

● Internal drawing of split 6wires

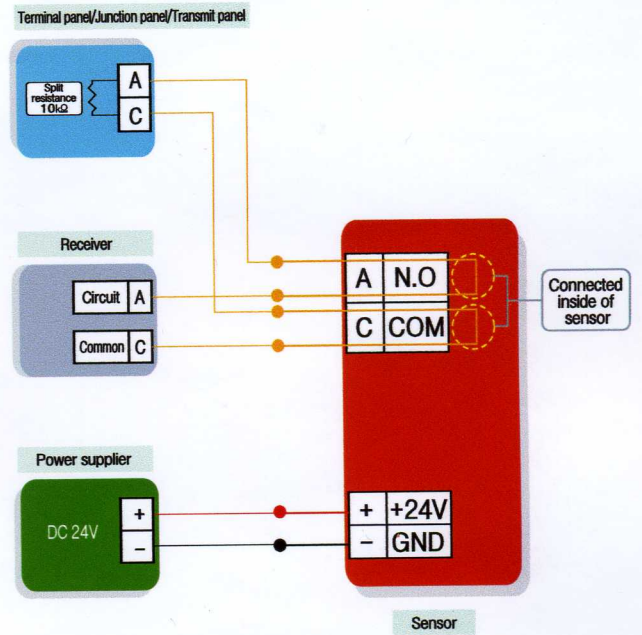

The flame detector is equipped with many kinds of fire output functions. One of them, relay signal(COM, N.O) has ON/OFF switch to make easy applying to general receiver or junction.

Product Installation

● Coupling method(In 0.13~0.15mm²)-Relay fire output(6lines standard)



Please stripe the covering and select 6 lines you want to use



Stripe right length the inner cover

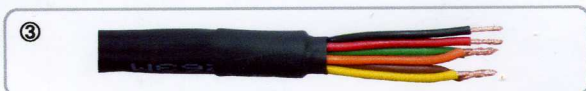

Twist green with orange and brown with yellow

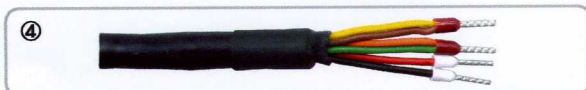

Stick the cord-end terminals and arrange them.
(If you don't have one, finish on No 3.)

	GND (-Power)
	+24V (+Power)
]N.O (Relay A connect point)
]COM (Relay connect point)

※This method based on 6 lines.
so, 4 lines or the others can
omit No 3.

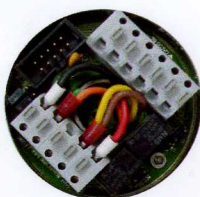

Terminal connection

● Recommended wire standard

- Diameter of wire(1/2") : Covered wire external cover diameter over 8mm below 10mm.
- For terminal slot : Stripe the cover about 10mm.

Nominal section size(mm²)

-Standard : 0.13~1.5

Example of possible wire

-Standard : 600TFR-CVVS(B), (T)FR-3, (T)FR-8,600HKIV

※ Upper standards are based on inner terminal. External connecting is followed by the Fire Services Act and designed capacity.

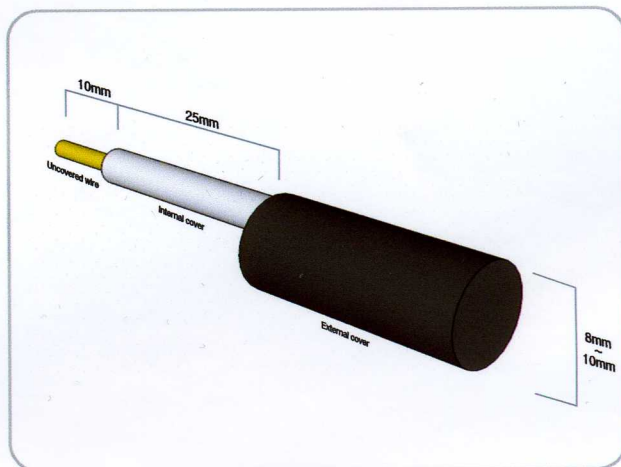

• Bracket

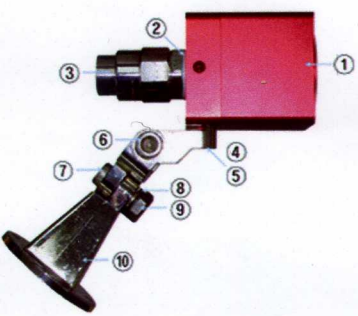

Names	
1.	Sensor
2.	Teflon washer
3.	Cable grand
4.	M6 spring washer
5.	M6-15 bolt
6.	M10-10 bolt
7.	M10-25 bolt
8.	M10 spring washer
9.	M10 nut
10.	Bracket

Spec	
Size	- 70 x 138
Weight	- 280g
Material	- Bracket (Aluminum, nickel coated)
	- Bolt, nut, washer (stainless steel)

• Bracket exterior

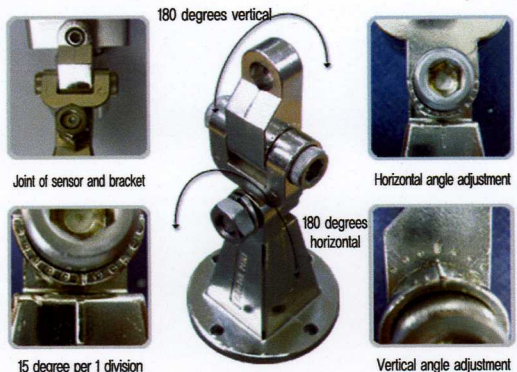

180 degrees vertical

Joint of sensor and bracket

Horizontal angle adjustment

180 degrees horizontal

Vertical angle adjustment

15 degree per 1 division

• Join of sensor

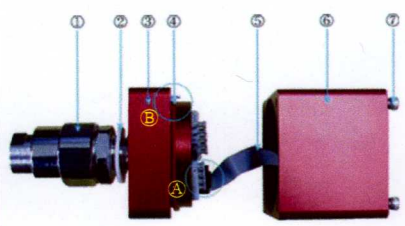

①	Cable grand
②	Teflon
③	Cover
④	Rubber ring
⑤	Connector cable
⑥	Body
⑦	M4 bolt
Ⓐ	Connector
Ⓑ	Groove

- Please connect to cover a. Connector of Sensor body then join body and cover. notice the wire not to twist at this time.
- Join correctly b. Groove, lock them tightly with 4 M4 bolt.

• Bracket Installation

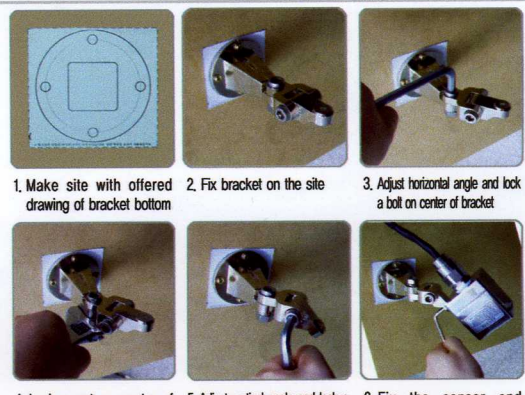

- Make site with offered drawing of bracket bottom
- Fix bracket on the site
- Adjust horizontal angle and lock a bolt on center of bracket
- Lock a nut on center of bracket
- Adjust vertical angle and lock a bolt on the head of bracket
- Fix the sensor and bracket with a bolt

Product Installation

● Explosion-proof type



RFD-2FT

RFD-2FTN

RFD-2FTN-I

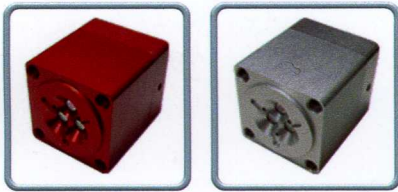

RFD-3FT

RFD-3FT-I

● Non explosion-proof type



RFD-2T

RFD-2TN-I

● Full shot of bracket

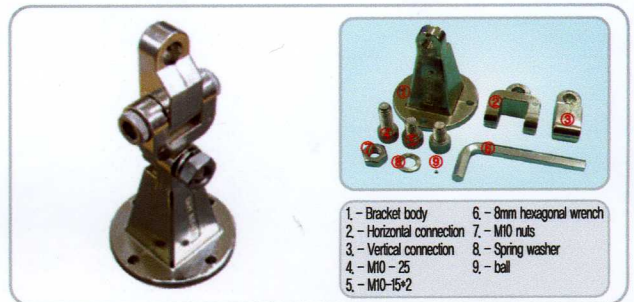

● Bottom drawing of bracket

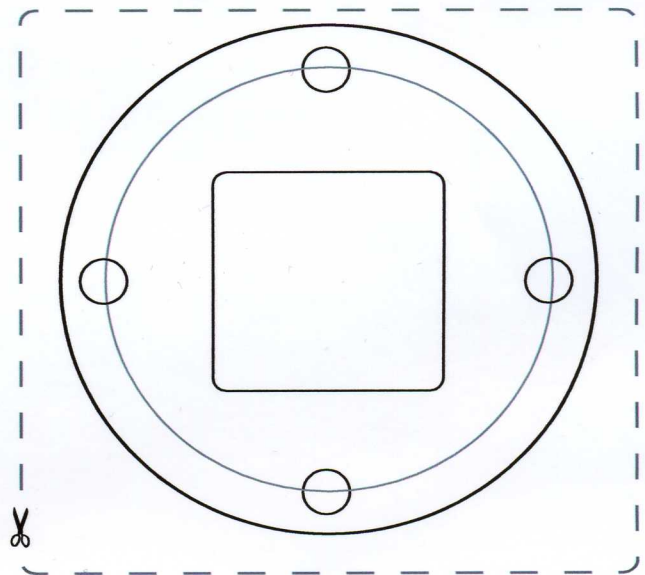

Product Installation

● Product installation

● Installation on the wall

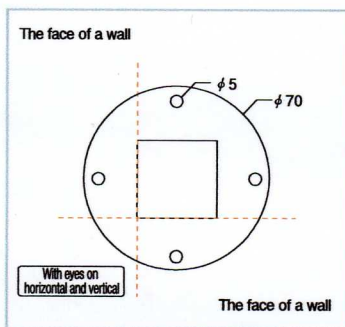

※ Fix the bracket not to fall off with bolts right for site condition.

● Joining installation on the structure

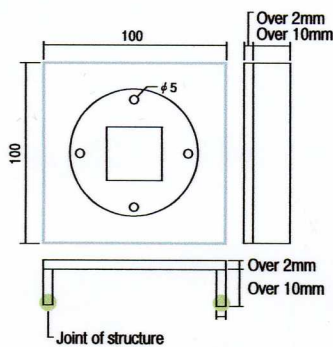

※ Upper figure for helps. Please consider the suitability with environment.

● Attentions in installation

● Attentions for explosion-proof(water-proof)type

1-bolt
2-join body and cover to press the rubber ring
3-Connector point of product and connector
4-Connector point of wire and connector
5-Contact point of connector and flexible cable
6-Flexible cable
7-Product body
8-Rubber ring
9-Product cover
10-Connector(Cable grand)
11-Flexible connector
12-Wire

※ Please refer to the attentions when assembling with needs of (explosion-proof, water-proof) water not to saturate into the product. Also, we recommend to use right class of stuff for the environment

● Right installation

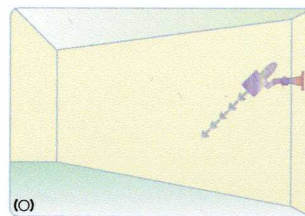

● Installation to avoid

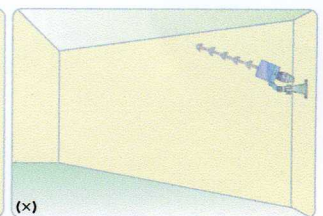

※ The flame detector is an optical sensor which analyzes properties of ray to recognize the fire. So, if you install the sensor's head up, it leaves the dust and dirt stack what affects correct sensing

**Product test &
Indicates of signals**

Product test

The REZONTECH flame detector is equipped with the delayed time system and pre-alarm system, working second by second. The delayed time system is set for 1,3,5 and 7 seconds to detect the fire and to generate the alarm. This flame detector is also equipped with the signal maintaining system and auto-recovery system. In 5 seconds since it detects the fire, the status goes automatically back to the beginning or it stays just as it detects unless the user resets

State	LED indicator	Explanation	Troubleshoot
Power Fail	Green LED Off	Power wire coupling or LED is bad	①
	Green LED Blinks	Electric voltage is bad(under 17V)	②
Idle	Green LED Blinks	Stand by fire dection	
Fire detect	Red LED Blinks	When it detects over proper level of fire, only blinks LED, not making alarm signal by Delay time	
Fire alarm	Red LED On	The length of time what discriminates is longer than Delay time, then it makes fire alarm signal	
Process of Reset	Green, Red, Blue(some of products) alternately blink	The detector is in process of reset	

- ① The red LED blinks when testing or starting the detector. If it doesn't blink, please check if the power is off.
- ② Please make sure that the electric voltage is higher than DC17V. If the electricity contains AC flow, please make sure that the practical DC voltage is higher than 17V. If it doesn't reach 17V, do not use this.

Product test Method

The REZONTECH flame detector senses flame by the correlation of fire source's flickering and the intensity of its radiant energy. And sensing distance is affected by the scale of fire(dimension).

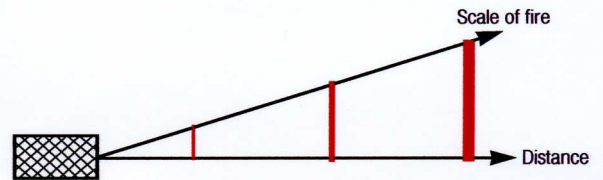



Test fire Source	Test distance	Target sensor of test	Test method
A lighter	Under 0.3m	All kinds of products	Turn on the lighter and roll from side to side
	Under 8m	RFD-2T, RFD-2FT	Tilt the torch to make the flame bigger
A gas torch	Under 9m	RFD-2FTN, RFD-2TN-I	Roll up and down to make the area of fire bigger
	Under 15m	RFD-3FT, RFD-3FT-I	
TL200	Under 2m	RFD-2T, RFD-2FT RFD-2FTN, RFD-2TN-I	Turn on the switch of TL200 and the light toward sensor window
TL300	Under 2m	RFD-3FT, RFD-3FT-I	Turn on the switch of TL300 and the light toward sensor window
FS-10	Under 30m	RFD-2T, RFD-2FT RFD-2FTN, RFD-2TN-I	Turn on the switch and ignite the gas in sight of sensor
	Under 50m	RFD-3FT, RFD-3FT-I	

* TL200, TL300 are the equipments for testing the flame detector. Inquiries about purchase or rent, please contact us, REZONTECH.

Product Test and Signal Indication

Sensitivity set

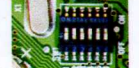
Model	RFD-2T	RFD-2FTN, RFD-2TN-I	RFD-2FT, RFD-3FT, RFD-3FT-I
Sensitivity	ON	ON	ON
Switch	OFF	OFF	OFF
			
	SW1 1 2 3 4 5 6	SW1 SW2 1 2 3 4 5 6 1 2 3	SW1 1 2 3 4 5 6
• Sensitivity set - Setting			
	Setting of sensitivity	Switch No.1-1	Switch No.1-2
	Lowest	on	on
	Low	off	on
	Medium	on	off
	High	off	off
• Delay time set - Setting the time required for the detector to sense the fire			
	Delay time (second)	Switch No.1-3	Switch No.1-4
	7	on	on
	5	off	on
	3	on	off
	1	off	off
• Setting of signal maintaining (Latching / Non Latching)-Signal state setting after fire detection.			
	Maintaining/or not	Switch No.1-5	If you set this disengaged, the signal reset within 5 sec. after fire extinguishing.
	Engaged	on	
	Disengaged	off	
• Setting of self diagnosis(self test) - A time in an hour			
	Self diagnosis	Switch No.1-6	Diagnose the faults of sensor or circuit of detector(fault display : LED or fault signal)
	Engaged	on	
	Disengaged	off	

Output and indicates of LED by situation

● RFD-2T, RFD-2FT, RFD-2TN-I, RFD-2FTN, RFD-2FTN-I

Sensor state	Cause	LED indicates
Power input	First operating	Alternately blink green and red for 3 sec
Idle	All OK and it stands by	Green LED is on
Warn signal(fire is recognized)	Both of UV/IR are sensed	Red LED blinks 1 time per sec
Fire alarm(fire is sensed)	When it senses the fire	Red LED is on

● RFD-3FT, RFD-3FT-I

Sensor state	Cause	LED indicates
Power input	First operating	Alternately blink green and red for 3 sec.
Idle	All OK and it stands by	Green LED is on
Warn signal(fire is recognized)	IR is sensed	Red LED blinks 1 time per sec.
Fire alarm(fire is sensed)	When it senses the fire	Red LED is on

Appendix

Accessories



Model : PSU-20



Model : PSU-05



Model : BK-1



Model : SUN SHIELD



Model : AIR SHIELD

Test equipment



Model : TL200



Model : TL300



Model : FS-20

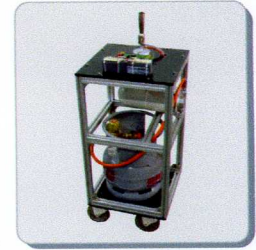

Model : FS-10

Inquires about purchase or rent, please contact us, REZONTECH

● How to use the test lamp TL200



- Range : 1m(Max. 5m)
- Application : UV/IR type flame detector
- Max duration time : 1 hour
- Weight : About 1.5kg
- Size : 185 x 75
- Casing : Aluminum(anodizing)

● Exterior



1. UV/IR lens 2. Hand grip 3. Operating switch 4. Recharging indicator 5. Recharging jack

● How to use

1. The test lamp point toward a sensor.
2. Press operating switch. (ON) [The light blinking is OK]
3. Locate the most bright light part on sensor.
4. Wait until the detector gets activated.
5. If the detector is not activating, then approach closer and repeat from 1 to 4.
6. Press operation switch. (OFF)
7. Recharge after use

● Attention

1. Please don't look directly the light from lamp.
2. Do not use any other recharger except those we offered.
3. Do not turn on the operating switch while recharger is connected.

● How to use the test lamp TL300



- Range : 1m(Max. 5m)
- Application : IR3 type flame detector
- Max duration time : 1 hour
- Weight : About 1.5kg
- Size : 185 x 75
- Casing : Aluminum(anodizing)

● Exterior



1. IR3 lens 2. Hand grip 3. Operating switch 4. Recharging indicator 5. Recharging jack

● How to use

1. The test lamp point toward a sensor.
2. Press operating switch. (ON) [The light blinking is OK]
3. Locate the most bright light part on sensor.
4. Wait until the detector gets activated.
5. If the detector is not activating, then approach closer and repeat from 1 to 4.
6. Press operation switch. (OFF)
7. Recharge after use.

● Attention

1. Please don't look directly the light from lamp.
2. Do not use any other recharger except those we offered.
3. Do not turn on the operating switch while recharger is connected.

● Test method of fire source



1. Identify the location of sensor for fire source test.



2. And then establish the coordinates and location for testing.
- Instruments : A tape measure, A laser meter, A Chalk



3. Fix the tester on the right position, not move.(Keep ready the extinguisher in preparation for fire.)



4. Check again the location of fire detector and run the tester.



5. Conclusion yes or no for operation and then finish the test.